

다이어트/운동 앱의 수용에 대한 결정요인: 채널확장이론을 중심으로[☆]

Factors of Leading the Adoption of Diet/Exercise Apps on Smartphones: Application of Channel Expansion Theory

조 재 회¹ 김 선 진¹
Jaehee Cho Sun Jin Kim

요 약

본 연구는 최근 들어 사용이 꾸준히 증가하고 있는 스마트폰 다이어트/운동 앱에 주목하면서, 채널확장이론(channel expansion theory)과 기술수용모델(technology acceptance model)에 기반하여, 세 가지 선행요인—인터넷 정보이용 효능감, 스마트폰 이용 효능감, 그리고 인터넷 정보에 대한 신뢰도—이 다이어트/운동 앱에 대한 태도 및 수용의도에 미치는 영향에 대해 분석했다. 경로분석 결과에 따르면, 인터넷 정보이용 효능감과 스마트폰 이용 효능감은 다이어트/운동 앱에 대한 인지된 사용 용이성(PEOU)에 정적인 영향을 미치고, 인터넷 정보에 대한 신뢰도는 해당 앱에 대한 인지된 유용성(PU)에 정적인 영향을 미치는 것으로 나타났다. 이에 더해, 인터넷 정보이용 효능감과 인터넷 정보에 대한 신뢰도가 다이어트/운동 앱에 대한 인지된 유용성에 미치는 영향은 성별에 따라 유의미한 차이를 보였다.

☞ 주제어 : 다이어트/운동 앱, 인터넷 정보 이용 효능감, 인터넷 정보 신뢰도, 채널 확장 이론, 기술수용모델

ABSTRACT

This study paid attention to the notable increase of the use of diet/exercise apps on smartphones. Based on channel expansion theory and technology acceptance model (TAM), this study investigated how three predictors—Internet information use efficacy, Internet information credibility, smartphone use efficacy—affected one's attitude toward and intention to use diet/exercise apps. Results from a path analysis indicated that Internet information use efficacy and smartphone use efficacy positively predict the perceived ease of use of diet/exercise apps. Internet information credibility positively predicts the perceived usefulness of such apps. Moreover, there were gender differences in the effects of both Internet information use efficacy and Internet information credibility on the perceived usefulness of diet/exercise apps.

☞ keyword : Diet/Exercise Apps, Internet Information Use Efficacy, Internet Information Credibility, Channel Expansion Theory, Technology Acceptance Model

1. Introduction

According to 2013 Mobile Internet Report, the amount of time and frequency of using the mobile Internet has continuously increased [1]. In 2013, people used the mobile Internet approximately 12.3 times and spent about 1.5 hours using it daily [1]. Particularly, among the various mobile

devices, there has been a distinguishable increase in the use of smartphones. Approximately 56.8% of smartphone users spent two hours per day on their phones. Compared to older users, younger users spent more time (2 hours and 53 minutes daily) using smartphones. More notably, 66.1% of smartphone users downloaded mobile app(s) for diverse purposes (e.g., game/entertainment, music, news, and video) in a given month [1].

In this way, there has been a continuous increase in using apps on smartphones. Moreover, corresponding to the increasing interest in well-being, the use of health-related apps has increased as well [2][3][4][5]. In the case of the U.S., 19% of smartphone owners were using health-related apps on

¹ School of Media & Communication, Chung-Ang University, Seoul, 156-756, Korea.

* Corresponding author (jcho49@cau.ac.kr)

[Received 13 November 2014, Reviewed 28 November 2014, Accepted 14 February 2015]

☆ This Research was supported by the Chung-Ang University Research Scholarship Grants in 2013.

smartphones in 2012, and the use of those apps are continuously increasing [6]. Among various health-related apps, people showed relatively greater interest in apps for fitness/exercise (38%) and diet/calorie counting (31%) [6]. Particularly, in the U.S., this trend of using diet/exercise apps will be closely related to the issues of obesity as well as preventive healthcare. In addition, because of relatively better health conditions as well as less experiences of chronic diseases, younger smartphone owners are more interested in using diet/exercise apps, compared to older users.

Corresponding to this increasing use of diet/exercise apps, researchers and practitioners have shown much interest in those technologies. However, since previous research has mainly explored the technical functions of those apps [7], there have been few studies scrutinizing the motivational factors that lead people to adopt and use such apps. Therefore, based on channel expansion theory and technology acceptance model (TAM), this present study aimed at examining the effects of three factors—smartphone use efficacy, Internet information use efficacy, and Internet information credibility—on individuals' intentions to adopt diet/exercise apps.

2. THEORETICAL BACKGROUND

2.1 CHANNEL EXPANSION THEORY

Supported by the development of various IT technologies, the constituents of contemporary society have come to use diverse forms of communication media. When there exist multiple forms of media, users need to select specific form(s) of media by considering the technical characteristics of media as well as the main purposes for which the media will be used. Previous studies have focused on the motivational processes of choosing particular media and have proposed various theories. Particularly, criticizing the limitations of media richness theory, Carson and Zmud proposed the channel expansion theory [8]. According to this theory, media richness is determined by individuals' experiences with using a certain type of medium. Thus, the more positive one's experience with a medium, the more positive one's attitudes toward it will be [8].

Although channel expansion theory has often been used by research on communication in organizational settings, a person's experience with a specific medium can affect his/her

attitudes toward the medium in mundane and ordinary contexts. Furthermore, channel expansion theory can be extended to a person's attitudes toward another medium similar to a previously used medium. For instance, when a person has positive experiences of using a specific form of smart device—e.g., tablet PC—s/he may show positive attitudes toward another form of smart device—e.g., smartphone. Therefore, paying attention to diet/exercise apps, this present study focused on two dimensions of media experiences. First, the extent of using smartphones can be directly related to the use of diet/exercise apps. Particularly, as a person can use smartphones more effectively in general, s/he may show more positive attitudes toward diet/exercise apps. Thus, this study analyzed the effect of smartphone use efficacy on attitudes toward diet/exercise apps. Secondly, the main function of diet/exercise apps is to search for information about diet and exercise, and this information-seeking is reliant on Internet searches. This implies that when a user is familiar with seeking diet/exercise information through the Internet and judges higher credibility of such information, s/he may show more positive attitudes toward diet/exercise apps. Consequently, this present study paid attention to Internet information use efficacy as well as Internet information credibility.

2.2 TECHNOLOGY ACCEPTANCE MODEL

In many academic disciplines, studies have actively applied the technology acceptance model (TAM) to various new technologies [9]. This model was based on two theoretical backgrounds—theory of reasoned action (TRA) and theory of reasoned behavior (TRB) [10][11][12][13]. The main point of these two theories is that a person's certain behavior is motivated by his/her attitudes toward an object, which are determined by his/her cognitions of the dominant characteristics of the object. Related to new technologies, TAM paid major attention to the micro-processes that determine one's attitudes toward a new technology, which largely depend on his/her perceptions of the technology and that finally lead him/her to adopt it.

TAM is composed of three constructs of variables. First, extended TAMs focus on the potential predictors that determine one's perceptions of a new technology [12][13]. For example, Svenson and colleagues investigated the effects of personality factors on one's perceptions toward a new

technology [13]. In addition to such personal factors, contextual and normative factors, such as social influence, have received attention from researchers [12]. In addition to these predictors, previous studies relying on extended TAMs have investigated various factors that determine one's attitudes toward a new technology. Therefore, depending on extended TAMs, this present study examined the potential roles of three predictors—smartphone use efficacy, Internet information use efficacy, and Internet information credibility—in determining one's perceptions of diet/exercise apps.

Next, Venkatesh and Davis proposed two main perceptual components of TAM—perceived usefulness (PU) and perceived ease of use (PEOU) of a technology. [11]. First, when a new technology is considered to be an effective tool for accomplishing a given task, the technology is understood to be of relatively high perceived usefulness (PU). For instance, when a new medical operator is perceived to be helpful for deducing more accurate diagnoses of a disease, this technology is high in PU. Next, perceived ease of use (PEOU) is determined by the amount of effort required to learn the ways of using a new technology. That is, when a person needs to take less effort to learn a new technology, its PEOU increases.

Lastly, another dimension of TAM is behavioral intention (BI) to adopt and use a new technology [11]. According to Davis and colleagues, BI is determined by the PU and PEOU of a new technology [9]. Based on previous research on TAM, this present study investigated the effects of PU and PEOU of diet/exercise apps on BI to adopt those apps.

3. HYPOTHESES BUILDING

As elaborated above, the main argument of channel expansion model is that individuals' positive experiences with using a specific medium is related to his/her positive attitudes toward the medium, finally leading the person to continue using the medium [8]. This explains the link between potential predictors and the two perceptual dimensions of TAM. In other words, one's previous experiences related to smartphone use as well as online information can serve as influential factors that determine attitudes toward extended use of the technology.

First, smartphone use efficacy and Internet information use efficacy can be conceptualized as the ability to efficiently use the given technology and information. In regards to smartphone

use efficacy, people, who better use smartphones, may have higher levels of knowledge and skills to efficiently use smartphones for various purposes, meaning a higher level of applicability of using smartphones. Here, it needs to be considered that PEOU is defined as the extent to which a person can easily learn a given technology, meaning that PEOU is positively related to the reduction of costs for learning the technology. Therefore, it is comprehensible that a person with greater capacity to effectively use a smartphone will experience less difficulty in learning additional functions—those in terms of diet/exercise apps in this study—related to a smartphone. Based on the same logic explaining this role of smartphone use efficacy, Internet information use efficacy can also be positively associated with the reduction of time and energy involved in one's use of diet/exercise apps that provide online diet/exercise information.

In addition, as elaborated above, the main assumption of channel expansion theory is that positive experiences with using a particular medium can lead to positive attitudes toward the medium, ultimately increasing use [7]. Based on this argument, it is plausible that, when a person is able to efficiently use a medium, s/he is more likely to experience positive attitudes toward the medium, and in the end, to actively adopt new functions provided by the medium.

Accordingly, relying on those arguments, this present study established the following hypotheses corresponding to smartphone use efficacy and Internet information use efficacy.

- H1.** Internet information use efficacy will be positively associated with the PEOU of diet/exercise apps.
- H2.** Smartphone use efficacy will be positively associated with the PEOU of diet/exercise apps.
- H3.** Internet information use efficacy will be positively associated with the PU of diet/exercise apps.
- H4.** Smartphone use efficacy will be positively associated with the PU of diet/exercise apps.

Next, we should also note that, according to previous research on information-seeking behaviors, although an appropriate amount of information is a necessary condition for enhanced performance, the quality of information also matters quite significantly [14]. Especially, in regards to health-related information, the credibility of information is one of the most

critical factors of determining one's behaviors of seeking such information [15]. Therefore, when a person gains credible health information through a particular communication channel, s/he may view the channel to be usefulness. Consequently, if a person judges the information from the Internet as highly credible, then s/he may expect higher usefulness in smartphone apps that provide users with Internet-based information. Therefore, this study developed the following hypothesis.

H5. Internet information credibility will be positively associated with PU of diet/exercise apps.

Next, previous studies depending on TAM have commonly observed positive effects of the PU and PEOU of a new technology on one's BI to adopt it [13]. Furthermore, PEOU also positively predicts PU of a new technology [10]. Finally, this study established the following hypotheses.

H6. PU of diet/exercise apps will positively affect BI to adopt those apps.

H7. PEOU of diet/exercise apps will positively affect BI to adopt those apps.

H8. PEOU of diet/exercise apps will positively affect PU of those apps.

Lastly, it has been often found that there exist gender differences in individuals' attitudes toward new technologies [16][17][18]. Moreover, studies that apply the theory of uses and gratifications (U&G) to understanding the use of new technologies have also pointed out gender differences in patterns of use [19]. Therefore, considering such findings, this study explored gender differences in attitudes toward diet/exercise apps through the following research question.

RQ1. How will the effects of the three predictors on PU and PEOU of diet/exercise apps differ by gender?

4. METHODS

4.1 PARTICIPANTS

For this study, an online survey was distributed to students from three universities located in either the city of Seoul or

the Gangwon-do province, Korea. In total, 277 usable surveys were collected and used for analysis. All survey participants had no experience using diet/exercise apps. Therefore, before proceeding to the questions about attitudes toward the apps, participants were instructed to view multiple snapshots of two diet/exercise apps. It was possible for them to go back and review the photos. Participants were female dominant (65.7%), and the average age of survey participants was 22.5 years. Most participants were undergraduate students (87.4%), and the others were graduate students. The median of monthly expenses was ₩400,000-₩500,000.

4.2 MEASUREMENTS

All variables were measured through 5-points Likert type scales (1=*Strongly Disagree*, 5=*Strongly Agree*). The internal consistency reliability (Chronbach's alpha) for all variables was acceptable (larger than .70). The mean score of the multiple items for each measurement was used for the analyses.

First, based on the scale of measuring Internet health information use efficacy, proposed by Yun and Park [20] this study newly developed nine items to measure smartphone use efficacy (SPUE). Two examples of the items are: 1) I know how to use smartphones in effective ways; and 2) I believe that I can use smartphones well. The reliability for this variable was acceptable ($\alpha = .85$, $M = 3.95$, $SD = .60$).

Second, Internet information use efficacy (IIFUE) was measured through four newly developed items, depending on Yun and Park's scale [20]. Examples of the items are: 1) I know the existence of usable information of diet and exercise on the web; and 2) I know how to search for diet/exercise information through the Internet in order to find answers to my questions about diet/exercise. The Chronbach's alpha for this variable was acceptable ($\alpha = .85$, $M = 3.60$, $SD = .70$).

Thirdly, in order to measure Internet information credibility (IIFFC), this study used four items. Examples are: 1) Diet/exercise information on the Internet is accurate; and 2) Diet/exercise information on the web is credible. This study obtained an acceptable reliability score for IIFFC ($\alpha = .88$, $M = 2.94$, $SD = .62$).

To validate the three predictors, a confirmatory factor analysis (CFA) was used. For more rigorous evaluation, three model fit indices were checked. They were the comparative

fit index (CFI, greater than .90), infinite fit index (IFI, greater than .90), and standardized root mean square (SRMR, smaller than .08). The CFA was conducted with AMOS 21. The results validated the proposed three-factor model (χ^2 (df = 116) = 401.9, CFI = .90, IFI = .90, SRMR = .06).

Next, three components of TAM were measured through items proposed by Davis and colleagues [9]. First, four items were used to measure the PU of diet/exercise apps. Examples are: 1) Diet/exercise apps will be useful for managing my health; and 2) For better health management, it will be useful to use diet/exercise apps. The reliability of PU of diet/exercise apps was acceptable ($\alpha = .92$, M = 3.33, SD = .75).

Second, PEOU and BI of diet/exercise apps were each measured through three items. An example of the items for PEOU is: It will be easy for me to learn the ways of using diet/exercise apps. An example for BI is: I want to use diet/exercise apps. Both PEOU and BI of diet/exercise apps showed acceptable reliability scores (PEOU: $\alpha = .91$, M = 3.63, SD = .69; BI: $\alpha = .93$, M = 2.66, SD = .90).

An additional CFA was conducted for the purpose of validating these three components of TAM. The analysis returned acceptable model fit indices for the three factor model, confirming the validity of the three variables (χ^2 (df = 32) = 72.9, CFI = .99, IFI = .99, SRMR = .03).

5. RESULTS

5.1 HYPOTHESES TESTS

In order to test the proposed hypotheses, this study conducted a path analysis as a specific form of structural equation modeling (SEM). AMOS 21 was used for this analysis, and the same three model fit indices were used to check the goodness-of-fit of the proposed model. Results from the path analysis supported the goodness-of-fit of the proposed model ($\chi^2 = 6.46$, df = 4, $p > .05$, CFI = .99, IFI = .99, SRMR = .03) (See Figure 1).

First, related to the PEOU of diet/exercise apps, Internet information use efficacy ($\beta = .23$, $p < .001$) and smartphone use efficacy ($\beta = .31$, $p < .001$) positively predicted the PEOU of diet/exercise apps. These results fully supported H1 and H2.

Second, as elaborated above, this study proposed the positive effects of three predictors on the PU of diet/exercise

apps on smartphones. Results from the path analysis showed that only Internet information credibility positively predicted the PU of diet/exercise apps ($\beta = .18$, $p = .01$). Consequently, while H5 was supported, H3 and H4 were rejected.

Thirdly, the remaining three hypotheses focused on the relationships among three components of TAM. Results from the path analysis showed that while PU strongly and positively affected BI to use diet/exercise apps ($\beta = .80$, $p < .001$), PEOU weakly and negatively predicted the same outcome variable ($\beta = -.13$, $p = .09$). Thus, while H6 was supported, H7 was rejected. In addition, supporting H8, PEOU's effect on PU of diet/exercise apps was statistically significant ($\beta = .58$, $p < .001$).

Lastly, in order to explore RQ1, a multi-group SEM was conducted, corresponding to the two gender groups. Then, each of the six paths from the three predictors to the PU and PEOU of diet/exercise apps was compared between the male and female groups. Results from the analysis show that there were significant gender differences in the effects of Internet information credibility and Internet information use efficacy on the PU of diet/exercise apps. More specifically, while Internet information use efficacy negatively and significantly affected the PU of diet/exercise apps among males ($\beta = -.19$, $p = .07$), its effect was not significant among females ($\beta = .11$, $p > .10$). The difference between the two regression coefficients was statistically significant ($z = -2.19$, $p = .03$). Next, the positive effect of Internet information credibility on the PU of diet/exercise apps was larger among males ($\beta = .36$, $p < .001$), compared to its effect among females ($\beta = .08$, $p > .10$). The difference between the two regression coefficients was statistically significant ($z = 1.98$, $p = .05$).

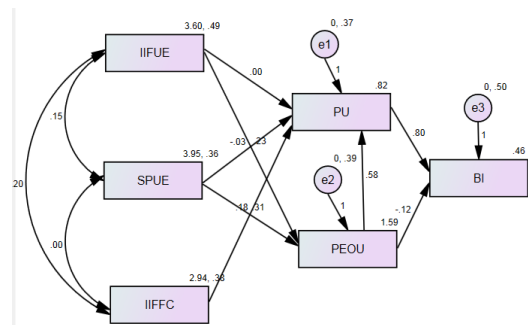

(Figure 1) Path Model

6. CONCLUSION

This present study investigated the effects of three predictors—Internet information use efficacy, Internet information credibility, and smartphone use efficacy—on individuals' attitudes toward diet/exercise apps and intentions to use them. According to SEM results, while Internet information use efficacy and smartphone use efficacy positively and significantly influenced the PEOU of diet/exercise apps on smartphones, Internet information credibility significantly affected the PU of those apps.

These results signify that Internet use through mobile devices can be linked to one's attitudes toward diet/exercise apps and, in the end, suggests the theoretical appropriateness of the channel expansion model for investigating patterns of diet/exercise app adoption. Moreover, the findings are theoretically and practically meaningful in the following ways. First, as elaborated above, we have little understanding of what influences people to adopt diet/exercise apps that have become increasingly popular. As a starting point of research on this topic, the present study explored and observed considerable connections between individuals' previous experiences with smartphone use and diet/exercise apps. Therefore, this study's findings can serve as empirical evidence for future research that will further analyze more various motivational factors that determine individuals' adoption and use of diet/exercise apps. Second, practically, this study suggests the need for app developers to pay more attention to potential users' previous experiences related to smartphones as well as online health information. That is, although it is critical to develop more unique, effective, and trendy apps, it will be difficult to attract potential users without fully comprehending their behavioral patterns smartphone use as well as online health-information seeking behaviors.

Furthermore, this present study explored gender differences in the three predictors' effects on the PU and PEOU of diet/exercise apps. Interestingly, among male smartphone users, Internet information use efficacy negatively affected the PU of diet/exercise apps. That is, when a male user is able to find diet/exercise information from the web in more effective ways, he will tend to report lower scores for the PU of diet/exercise apps. Moreover, the effect of Internet information

credibility on the PU of diet/exercise apps was significant only among males. These results suggest that it is necessary to develop diet/exercise apps that provide unique and credible diet/exercise information in order to encourage males' adoption of those apps.

Although the present study provides meaningful findings in terms of the adoption of diet/exercise apps, the following points need to be considered for future research. First, because the samples for this study were female dominant (65.7%), it has the limitation in regards to generalization of the main findings. Therefore, future research needs to obtain more representative samples. Second, future research will need to collect data from an elder population, because of the increasing use of smartphones among older people. Thus, further analysis of generational differences in adopting diet/exercise apps is recommendable. Next, more control variables need to be considered for more thorough investigation. For instance, the extent to which a person is interested in diet/exercise may influence the adoption of diet/fitness apps. Likewise, other variables, which can be closely related to diet/exercise activities, need to be controlled in order to scrutinize the true effects of those three predictors of PU and PEOU of diet/exercise apps.

References

- [1] J. Yim, J. Yoo, S. Chang, J. Lee, J. Yoo, "2013 Mobile Internet Report," *Korea Internet & Security Agency*, 2013.
- [2] C. Kratzke, C. Cox, "Smartphone Technology and Apps: Rapidly Changing Health Promotion," *International Electronic Journal of Health Education*, Vol. 15, pp. 72-82, 2012.
- [3] M. E. Morris, Q. Kathawala, T. K. Leen, E. E. Gorenstein, F. Guilak, M. Labhard, W. Deleeuw, "Mobile Therapy: Case Study Evaluations of a Cell Phone Application for Emotional Self-Awareness," *Journal of Medical Internet Research*, Vol. 12, no. 2, e10, 2012.
<http://dx.doi.org/10.2196/jmir.1371>
- [4] M. C. Carter, V. J. Burley, C. Nykjaer, J. E. Cade, "Adherence to a Smartphone Application for Weight Loss Compared to Website and Paper Diary: Pilot Randomized Controlled Trial," *Journal of Medical Internet Research*,

- Vol. 15, no. 4, e32, 2013.
<http://dx.doi.org/10.2196/jmir.2283>
- [5] M. Kirwan, C. Vandelanotte, A. Fenning, M. Duncan, "Diabetes Self-Management Smartphone Application for Adults with Type 1 Diabetes: Randomized Controlled Trial," *Journal of Medical Internet Research*, Vol. 15, no. 11, e235, 2013. <http://dx.doi.org/10.2196/jmir.2588>
- [6] S. Fox, M. Duggan, "Mobile Health 2012," *PEW Research Center*, 2013.
<http://www.pewinternet.org/2012/11/08/mobile-health-2012/>
- [7] J. H. West, P. C. Hall, Vc. Arredondo, B. Berrett, B. Guerra, J. Farrell, "Health Behavior Theories in Diet Apps," *Journal of Consumer Health on the Internet*, Vol. 17, no. 1, pp. 10-24, 2013.
<http://dx.doi.org/10.1080/15398285.2013.756343>
- [8] J. R. Carlson, R. W. Zmud, "Channel Expansion Theory and the Experiential Nature of Media Richness Perceptions," *Academy of Management Journal*, Vol. 42, no. 2, pp. 153-170, 1999.
<http://dx.doi.org/10.2307/257090>
- [9] F. D. Davis, R. P. Bagozzi, P. R. Warshaw, "User Acceptance of Computer Technology: A Comparison of Two Theoretical Models," *Management Science*, Vol. 35, pp. 982-1003, 1989.
<http://dx.doi.org/10.1287/mnsc.35.8.982>
- [10] N. Park, Y. Kim, H. Y. Shon, H. Shim, "Factors Influencing Smartphone Use and Dependency in South Korea," *Computers in Human Behaviors*, Vol. 29, pp. 1763-1770, 2013.
<http://dx.doi.org/10.1016/j.chb.2013.02.008>
- [11] V. Venkatesh, F. D. Davis, "A Theoretical Extension of the Technology Acceptance Model: Four Longitudinal Field Studies," *Management Science*, Vol. 46, pp. 186-204, 2000.
<http://dx.doi.org/10.1287/mnsc.46.2.186.11926>
- [12] V. Venkatesh, M. G. Morris, G. B. Davis, F. D. Davis, "User Acceptance of Information Technology: Toward a Unified View," *MIS Quarterly*, Vol. 27, no. 3, pp. 425-478, 2003.
- [13] G. B. Svendsen, J. K. Johnsen, L. Almås-Sørensen, J. Vittersø, "Personality and Technology Acceptance: the Influence of Personality Factors on the Core Constructs of the Technology Acceptance Model," *Behavior & Information Technology*, Vol. 32, no. 4, pp. 323-334, 2013. <http://dx.doi.org/10.1080/0144929X.2011.553740>
- [14] J. Mai, "The Quality and Qualities of Information," *Journal of the American Society for Information Science and Technology*, Vol. 64, no. 4, pp. 675-688, 2013.
<http://dx.doi.org/10.1002/asi.22783>
- [15] Z. Wang, J. B. Walther, S. Pingree, R. P. Hawkins, "Health Information, Credibility, Homophily, and Influence via the Internet: Web Sites versus Discussion Groups," *Health Communication*, Vol. 23, no. 4, pp. 358-368, 2013.
<http://dx.doi.org/10.1080/10410230802229738>
- [16] V. Ilie, C. V. Slyke, G. Green, H. Lou, "Gender Differences in Perceptions and Use of Communication Technologies: A Diffusion of Innovation Approach," *Information Resources Management Journal*, Vol. 18, no. 3, pp. 13-31, 2005.
<http://dx.doi.org/10.4018/irmj.2005070102>
- [17] H. Wang, S. Wang, "User Acceptance of Mobile Internet Based on the Unified Theory of Acceptance and Use of Technology: Investigating the Determinants and Gender Differences," *Social Behavior and Personality: An International Journal*, Vol. 38, no. 3, pp. 415-426, 2010.
<http://dx.doi.org/10.2224/sbp.2010.38.3.415>
- [18] H. Nysveen, P. E. Pedersen, H. Thorbjørnsen, "Explaining Intention to Use Mobile Chat Services: Moderating Effects of Gender," *Journal of Consumer Marketing*, Vol. 22, no. 5, pp. 247-256, 2005.
<http://dx.doi.org/10.1108/07363760510611671>
- [19] N. Park, K. F. Kee, S. Valenzuela, "Being Immersed in Social Networking Environment: Facebook Groups, Uses and Gratifications, and Social Outcomes," *Cyberpsychology & Behavior*, Vol. 12, no. 6, pp. 729-733, 2009.
<http://dx.doi.org/10.1089/cpb.2009.0003>
- [20] E. K. Yun, H-A. Park, "Consumers' Disease Information-Seeking Behavior on the Internet in Korea," *Journal of Clinical Nursing*, Vol. 19, pp. 2860-2868.

◎ 저 자 소 개 ◎



조 재 희 (Jaehee Cho)

2003년 서강대학교 신문방송학과 학사

2006년 텍사스 주립대 커뮤니케이션학과 석사

2011년 텍사스 주립대 커뮤니케이션학과 박사

2011년 - 2013년 University of North Carolina at Charlotte, Department of Communication Studies,
Assistant Professor

2013년 - 현재 중앙대학교 미디어 커뮤니케이션학부 조교수

관심분야: 뉴미디어 수용



김 선 진 (Sun Jin Kim)

2010년 부산외국어 대학교 이탈리아학과 학사

2013년 - 현재 중앙대학교 미디어 커뮤니케이션학부 석사과정

관심분야: 소셜 미디어 이용